

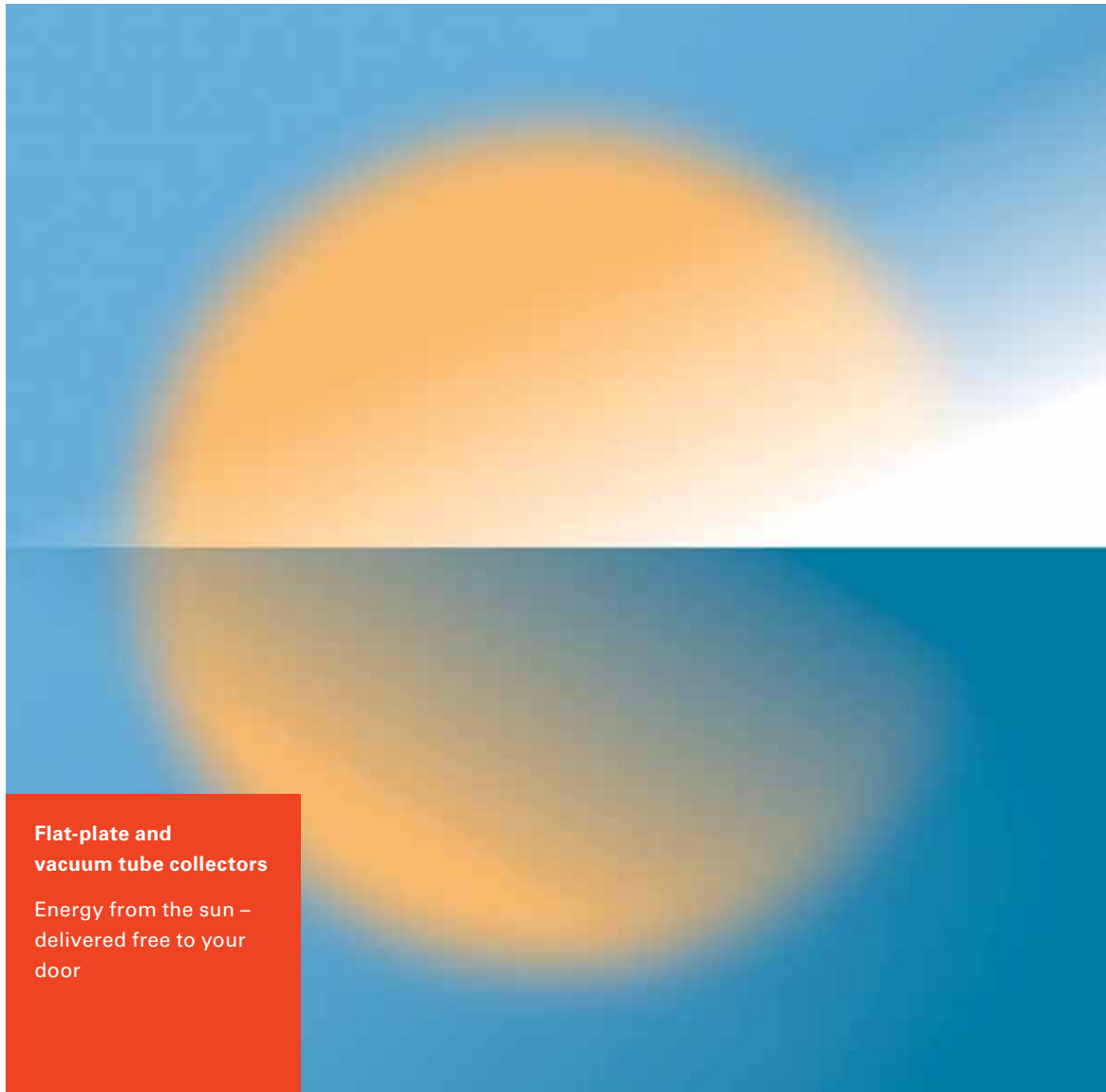

TECHNOLOGY BROCHURE

Solar thermal systems **VITOSOL**



**Flat-plate and
vacuum tube collectors**

Energy from the sun –
delivered free to your
door



Energy from the sun – delivered free to your door

Anyone investing in a new heating system today should design it to include a solar thermal system from the outset. This will allow you to benefit from lower energy consumption and also look forward to lower monthly energy bills.

By installing solar collectors, you are demonstrating your commitment to protecting the environment by sustainably lowering CO₂ emissions. With Viessmann technology you are opting for a futureproof system in which all components interact optimally.

Investing in solar technology also increases the value of your property.

On the following pages, you will find comprehensive information about the possibilities open to you with Viessmann solar technology for energy efficient DHW heating and central heating backup.

With more than 40 years' experience in the development and manufacture of solar thermal systems, you can count on our high quality and our technical expertise.

All Viessmann systems are designed to work in combination with solar technology, so it makes no difference whether you opt for a new condensing boiler for oil or gas, a heating system for wood, or a heat pump.

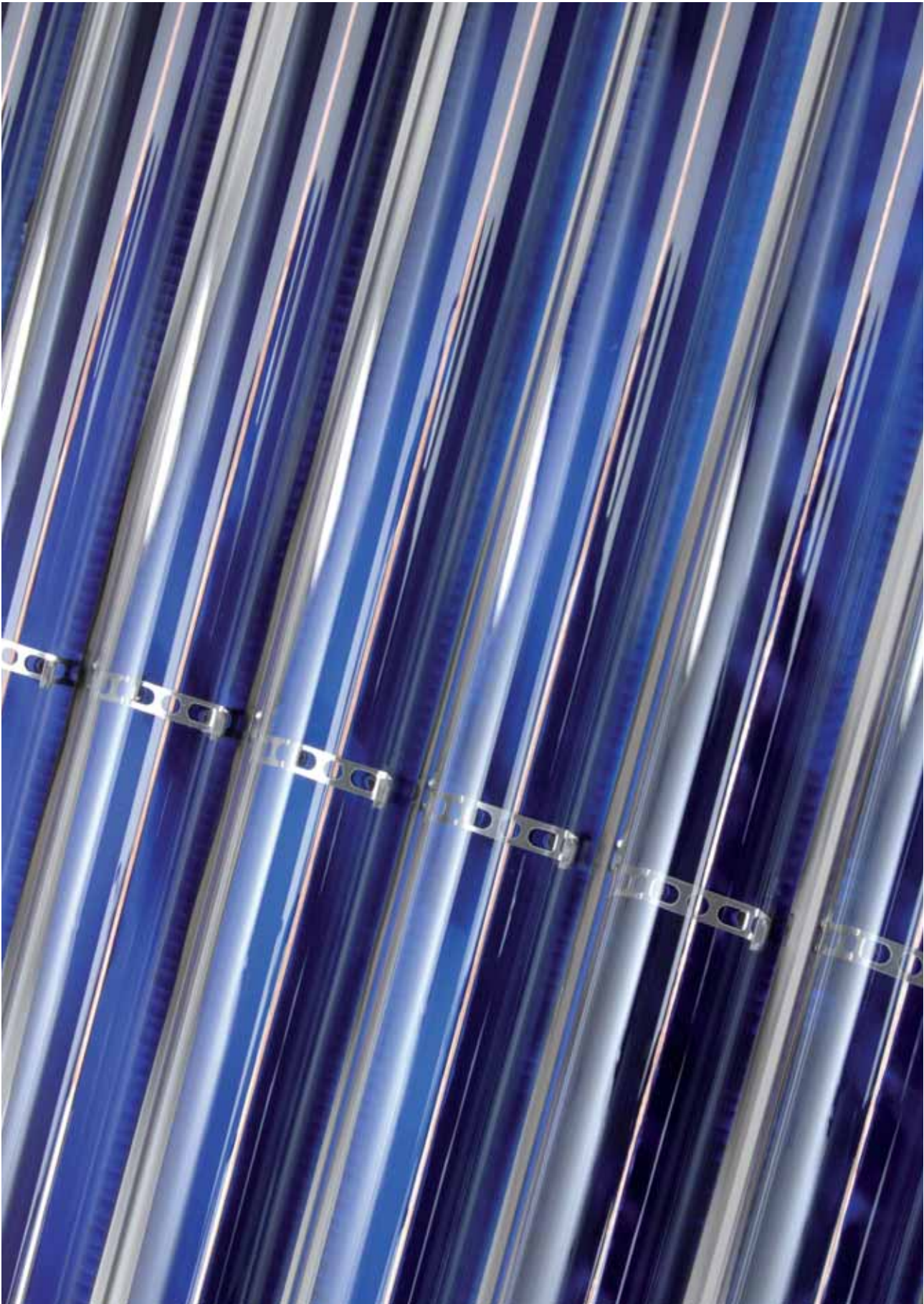



6

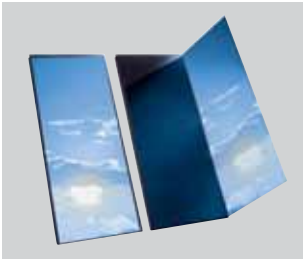

10



12



28



30



32

Viessmann flat-plate and vacuum tube collectors meet every requirement for efficient and cost effective DHW heating and central heating backup.

6 SAVE ENERGY AND PROTECT THE CLIMATE

Find out why it is worth modernising your heating system now and incorporating an efficient solar thermal system. In doing so, you will be making an active and sustainable contribution towards protecting the climate and using less fossil fuel.

10 THERMPROTECT: AUTOMATIC OVERHEATING PROTECTION

The globally unique ThermProtect automatic temperature-dependent shutdown in the Vitosol 200-FM and Vitosol 100-FM flat-plate collectors and the new Vitosol 300-TM and Vitosol 200-TM tube collectors reliably prevents collectors from overheating.

12 SOLAR TECHNOLOGY

The flat-plate and vacuum tube collectors from the Vitosol series can be optimally matched to the relevant energy demand.

28 CONVENIENCE AND COST EFFICIENCY BY DESIGN

Use the most advanced system technology to control your heating and solar thermal system. The intelligent Vitosolic energy management system communicates very effectively with the heating control unit, significantly lowering heating bills.

30 SERVICE THAT COVERS EVERY ASPECT OF SOLAR TECHNOLOGY

Make the most of our trade partners. They will tell you all you need to know about bespoke heating and solar technology, subsidy opportunities and finance options.

32 THE COMPANY

The power of innovation: a family business for three generations, Viessmann offers state of the art technology and takes its responsibilities seriously.



1300 1250 1200 1150 1100 1050 1000 950 900

Global radiation

kWh/(m² x year)

Save energy and protect the climate

In Germany alone, there are still around two million heating systems in use today that are more than 25 years old. Their owners are often completely unaware of how much energy these systems waste, as they allow a great deal of unused heat to simply escape up the chimney. Furthermore, these old systems have an impact on our climate through unnecessary CO₂ emissions which contribute to global warming.

Saving energy

Anyone investing in a new heating system today should design it to include a solar thermal system from the outset. By installing solar collectors, you are demonstrating your commitment to protecting the environment by saving energy and sustainably lowering CO₂ emissions.

Protect resources

Around one third of the total energy demand in Germany is expended on heating buildings. Energy conscious construction and economical heating systems, such as those that employ condensing technology, can substantially reduce this consumption. This then contributes to the preservation of resources and to the protection of the Earth's atmosphere.

One important area of potential savings is offered by DHW heating. In our latitudes, solar collectors combined with a DHW cylinder represent the most interesting alternative to boiler operation, especially during the summer months. Even during spring and autumn, you may often be able to turn off your boiler when using solar energy to back up your central heating.

Public subsidies

Public subsidies can be claimed for the purchase of solar thermal systems in Germany. Furthermore, the investment pays off in only a few years because of the large amount of energy saved. For up to date overviews, see www.viessmann.de.

In a detached house, solar energy covers up to 60 % of the energy required for heating DHW.

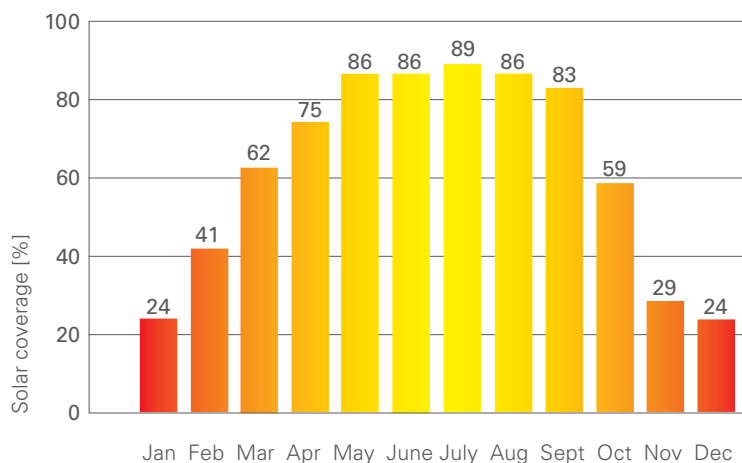

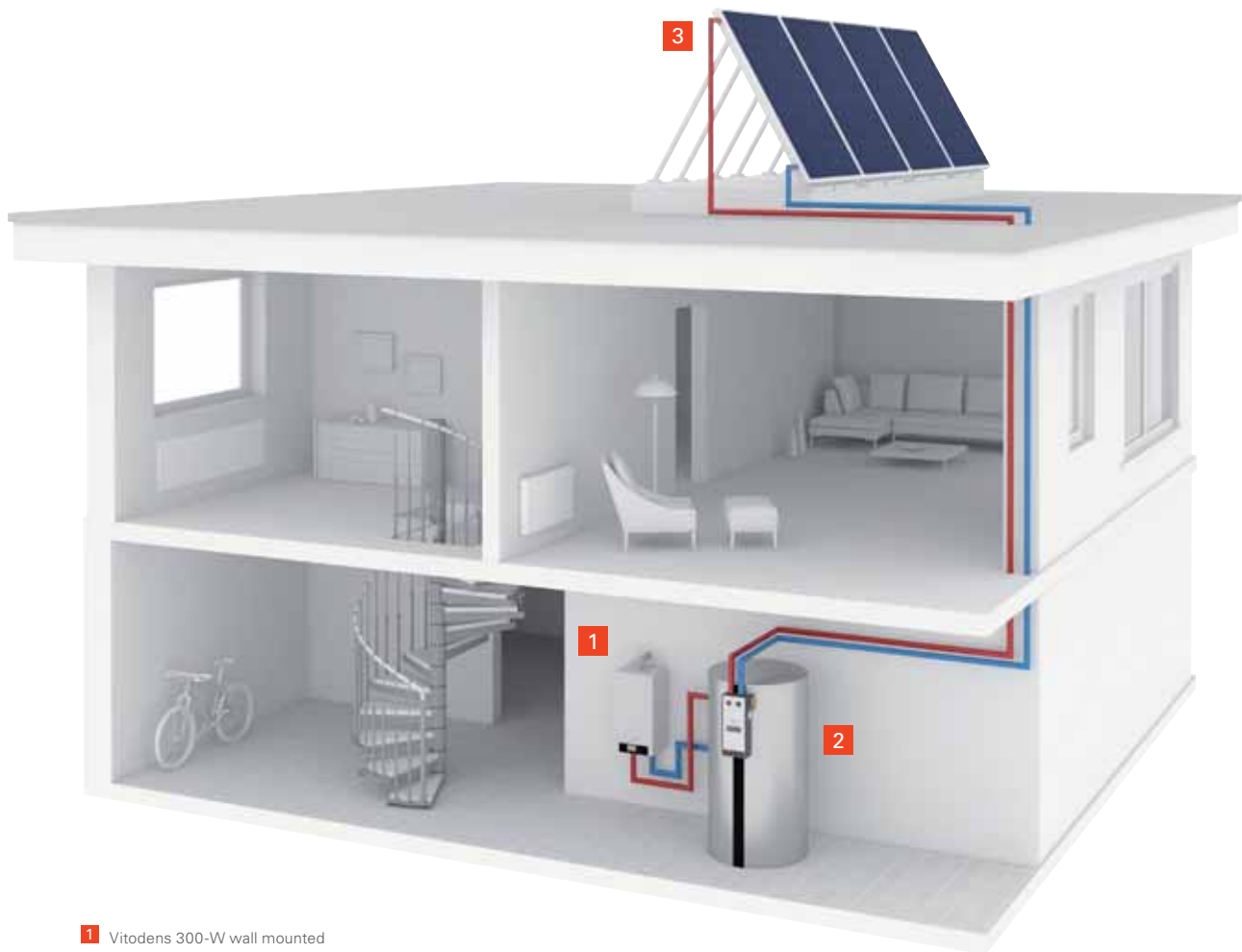

- 1 Vitodens 300-W wall mounted gas condensing boiler
- 2 Vitocell 360-M multi mode combi cylinder for DHW heating and central heating backup with attached Solar-Divicon
- 3 Vitosol 200-FM flat-plate collectors

Energy efficiency class: A
in combination with
solar collectors

A+

With Viessmann, heating and solar technology come entirely from a single source. All components are perfectly matched.

DHW heating and central heating backup with solar energy

Solar thermal systems are the perfect choice for DHW heating and central heating backup. By harnessing freely available solar energy, you can save on the use of fossil fuels. What's more, investments in solar thermal energy pay off in just a few years.

Fundamentally, you have the option of using solar energy for DHW heating and central heating backup. Savings on oil and gas are considerable in all cases, as you will be able to reduce your annual energy consumption by around 60 percent. This is the energy that would otherwise be required for your day to day DHW heating. If you combine the heating of DHW and heating water, you will save around 35 percent of the total energy required – every year.

Solar thermal system with dual mode DHW cylinder

A dual mode DHW cylinder is central to this type of system. When there is sufficient insolation, the solar medium in the solar thermal system heats up the water in the DHW cylinder via the lower indirect coil.

When the temperature drops through hot water being drawn off, such as for a bath or shower, the boiler starts – if necessary – to provide additional heating via the second circuit.

Solar thermal system for DHW heating and central heating backup

The solar medium heated in the solar collectors can be used to bring heating water and DHW up to temperature. For this, the heating circuit, via a heat exchanger, uses the water in the solar cylinder that is continuously heated by the solar collectors. The control unit checks whether the required room temperature can be achieved. If the temperature is below the set value, the boiler will also start.

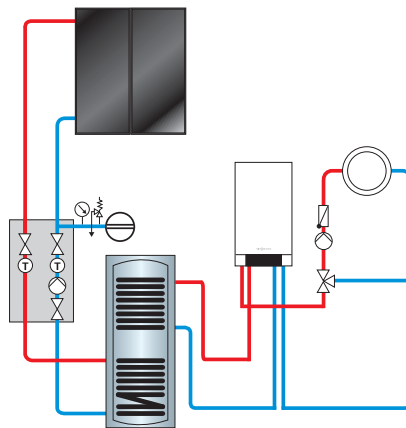

Solar DHW heating

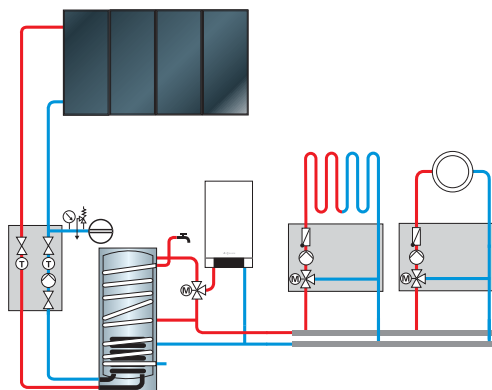

Solar DHW heating and central heating backup

ThermProtect, with its innovative automatic shutdown function, protects Vitosol flat-plate and vacuum tube collectors from overheating

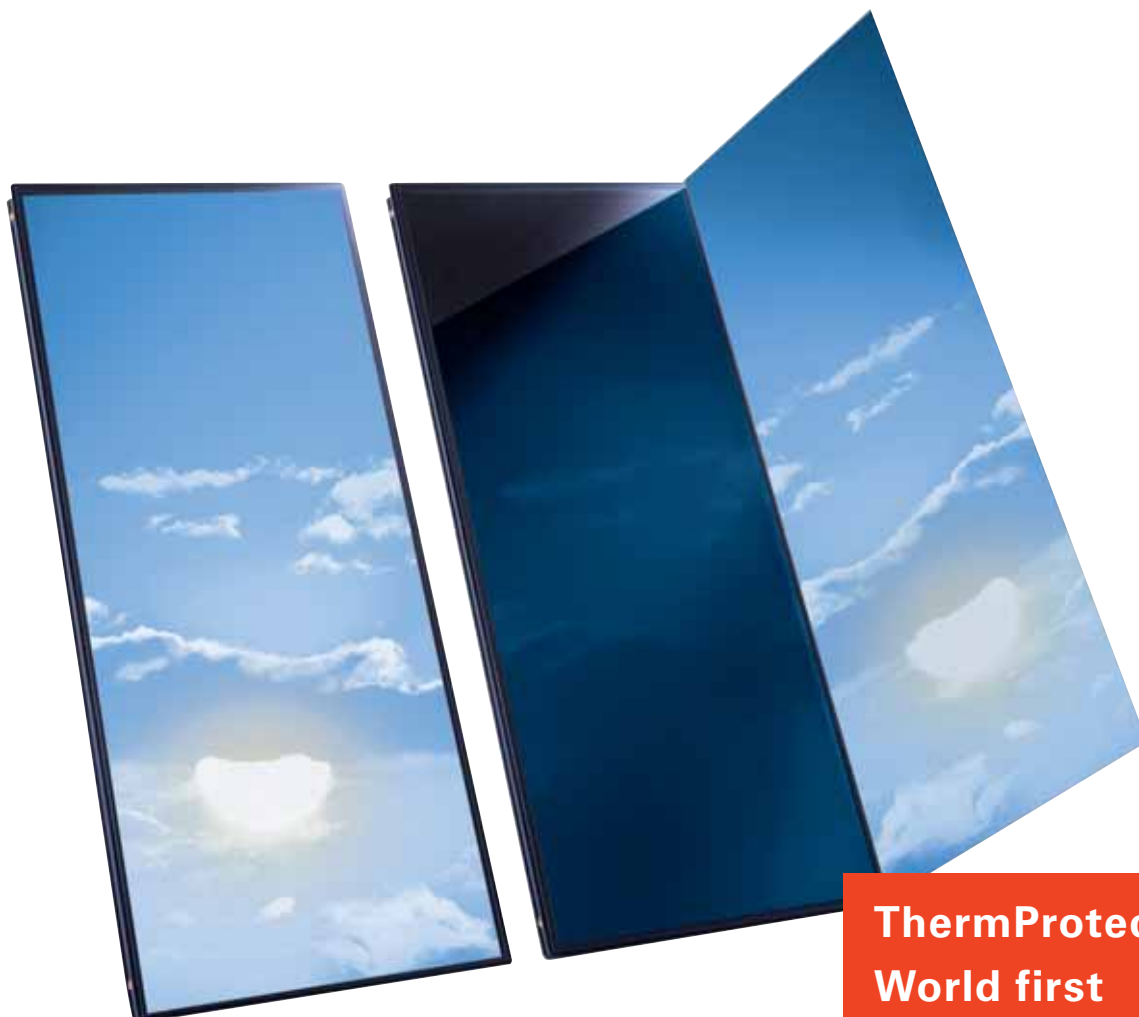

**ThermProtect
World first**

With ThermProtect automatic temperature-dependent shutdown in the Vitosol 200-FM and Vitosol 100-FM flat-plate collectors, Viessmann set a benchmark for efficient, operationally reliable solar thermal systems. Now Vitosol 300-TM and Vitosol 200-TM vacuum tube collectors also feature this automatic shutdown facility, for reliably preventing the collectors from overheating.

**Solar thermal systems with
ThermProtect: durable and
reliable**

Thanks to ThermProtect, large collector areas can also be realised without having to take stagnation into consideration during system engineering. Viessmann's technology causes the collectors to shut down when a set temperature limit is reached. The temperature-dependent shutdown functions completely independently of collector system configuration, control unit settings and installation location. The thermal loads on system components and the heat

transfer medium always stay within their normal range. This increases service life and operational reliability, compared to conventional solar thermal systems.

Simpler installation

Installation is easier, as there is no need for pre-cooling vessels or stagnation coolers. As the formation of steam from the heat transfer medium no longer has to be taken into consideration for the collectors, there are also more options when it comes to routing the hydraulic lines.

Vitosol 200-FM and Vitosol 100-FM: crystals prevent overheating

A crystalline absorber coating on the Vitosol 200-FM and Vitosol 100-FM flat-plate collectors controls energy absorption. In physical terms, the ThermProtect coating function is ensured by temperature-dependent changes in the structure of the crystals. At collector temperatures of around 75 °C and above, the reflection of incoming solar radiation is increased. Further temperature rises are limited, reliably preventing the formation of steam.

Once the temperature in the collector falls again, the crystalline structure returns to its original state. The energy drawn by the collector is then no longer irradiated back into the environment and can be used in the solar thermal system. There is no limit to the number of times the change in crystalline structure can be activated, making this function permanently available.

Vitosol 300-TM and Vitosol 200-TM: heat pipe with automatic temperature-dependent shutdown

In the new Vitosol 300-TM and Vitosol 200-TM vacuum tube collectors, a self-regulating heat pipe dry-connected inside the collector heat exchanger is responsible for the ThermProtect automatic temperature-dependent shutdown. Solar energy causes the medium sealed inside the heat pipe to evaporate. When it reverts to its liquid state inside the condenser, the heat absorbed is transferred to the solar thermal system and the medium flows back to the sunlit area of the vacuum tube.

Once the temperature limit of approx. 120 °C is reached, the medium is no longer able to condense. Thanks to this phase-change temperature shutdown, heat transfer is interrupted and the system is thus protected against excessively high stagnation temperatures. Circulation in the heat pipe only restarts at lower collector temperatures, and solar energy can once again be transferred to the heating system.

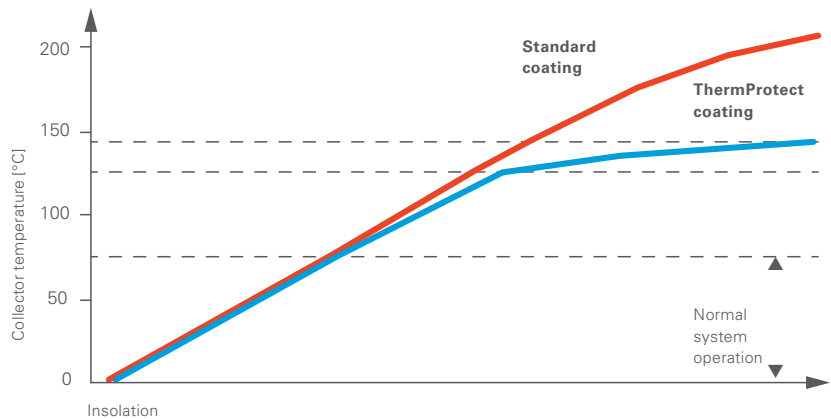

In standard collector mode, the ThermProtect coating of the flat-plate collectors acts like any conventional absorber coating. At collector temperatures of 75 °C and above, heat transfer increases many times over, reliably preventing overheating and the formation of steam in the event of stagnation.

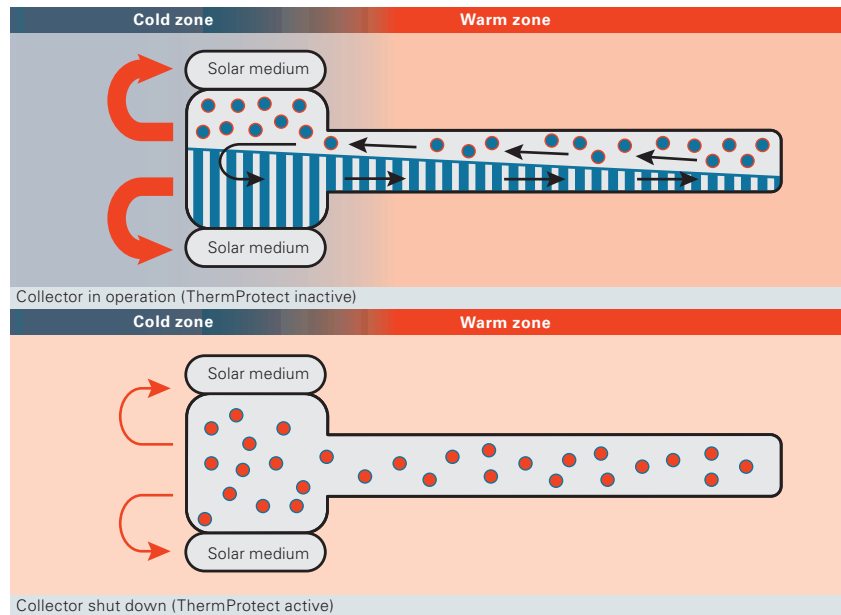

The self-regulating heat pipe in the Vitosol 300-TM and Vitosol 200-TM vacuum tube collectors works as follows: once the temperature limit of approx. 120 °C is reached, the medium is no longer able to condense, so heat transfer is interrupted and the system is thus protected against excessively high stagnation temperatures.



VITOSOL

With a wide range of flat-plate and vacuum tube collectors, Viessmann provides flexible and individual solutions for every kind of modern heating system.

Every year, the sun radiates on average 1000 kWh onto every square metre of ground in central Europe. This corresponds to the energy content of 100 litres of fuel oil. With Viessmann solar collectors, you can utilise this energy to generate heat. A solar thermal system is the ideal extension to any heating system, and sustainably lowers energy consumption.

The heating system that loves the environment

Even when it comes to environmental compatibility, with Viessmann solar thermal systems you'll be on the sunny side of the street: on average, annual carbon dioxide (CO₂) emissions are reduced by about three quarters of a tonne for a detached house.

Futureproof in every respect

Viessmann flat-plate and tube collectors are distinguished by their high operational reliability and long service life. The Vitosol solar collectors are made of corrosion and UV-resistant materials. This is most impressively verified by quality tests according to the EN 12975 test standard or ISO 9801, which at the same time confirm the consistently high thermal output.

Viessmann can draw on more than 30 years of experience in the development and manufacture of solar collectors.



VITOSOL 300-TM

(type SP3C)

Vacuum tube collectors with heat pipe technology and ThermProtect
Absorber area: 1.26, 1.51 and 3.03 m²

Page 14



VITOSOL 200-TM

(type SPEA)

Vacuum tube collectors based on the heat pipe principle with ThermProtect
Absorber area: 1.63 and 3.26 m²

Page 14



VITOSOL 200-FM

(Type SV2F and SH2F, type SV2G and SH2G)

Flat-plate collectors with ThermProtect
Absorber area: 2.32 m²

Page 20



VITOSOL 100-FM

(types SV1F and SH1F)

Flat-plate collectors with ThermProtect
Absorber area: 2.32 m²

Page 20



VITOSOL 141-FM

DHW solar pack comprising Vitosol 100-FM flat-plate collectors (type SVKF for above roof installation, type SVKG for roof integration) and Vitocell 100-B/-W (type CVBA) with 250 litre capacity

Page 24



Highly efficient vacuum tube collectors based on the heat pipe principle and ThermProtect

The absorbers with highly selective coating collect a vast amount of solar energy and thereby ensure high efficiency. At the same time, the vacuum in the tubes provides very effective thermal insulation. This means there are almost no losses between the glass tubes and the absorber, enabling the collector to convert even low levels of insolation into useful heat. The vacuum tube collectors use the available insolation extremely efficiently, particularly in the spring and autumn and in the winter when outside temperatures are low.

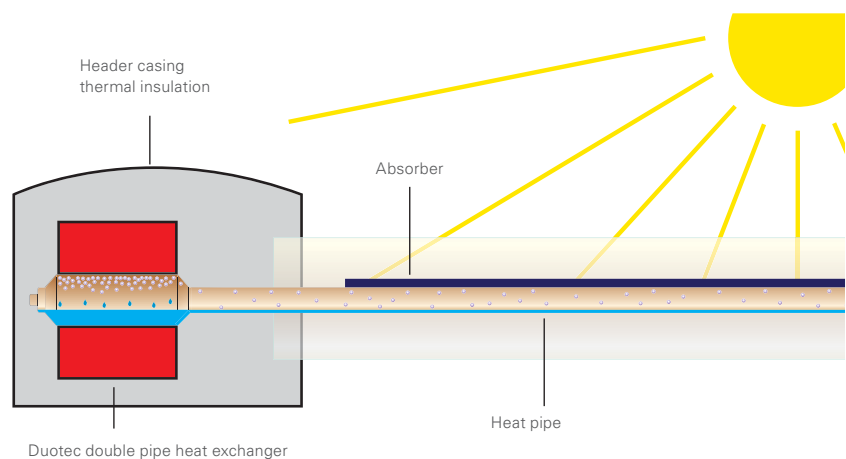

The medium heated by the sun evaporates and shifts to the colder part of the tube. There, the steam condenses, transferring the heat to the header, and the water is then reheated in a new cycle.

High energy yields for years to come

Viessmann solar collectors are designed for an exceptionally long service life. This is guaranteed by the use of high grade, corrosion-resistant materials, such as glass, aluminium, copper and stainless steel. The absorber is an integral part of the vacuum tube. This protects it from weather influences and contamination, and ensures high energy yields for years to come.

Heat pipe principle for high operational reliability

The Vitosol 300-TM and Vitosol 200-TM are highly efficient vacuum tube collectors based on the heat pipe principle.

In heat pipe systems, the solar medium does not flow directly through the tubes. Instead, a process medium evaporates in the heat pipe below the absorber and transfers the heat to the solar medium. The dry connection of

the heat pipes inside the header, the low fluid content inside the collector and the ThermProtect automatic temperature-dependent shutdown ensure particularly high operational reliability.

Quick and safe installation

Vitosol tube collectors are delivered as an assembled module. An innovative push-fit system enables the tubes to be quickly and easily installed. The tubes can be rotated individually for optimum alignment with the sun. The tubes are connected in a dry state, i.e. without direct contact between the process medium and the solar medium, allowing individual tubes to be replaced without draining the system. The stainless steel corrugated pipe push-fit connectors interconnect the individual collectors.

The Vitosol 300-TM high performance vacuum tube collector meets the highest demands for efficiency and safety

The Vitosol 300-TM high performance collector is one of the most efficient models on the market. It is particularly recommended for use in restricted spaces. The absorber angle can be adjusted by $\pm 25^\circ$ to deliver an exceptionally high yield, even when the sun is in less favourable positions. The collector can be installed and used in any position and is designed for use on detached houses and apartment buildings. It features ThermProtect automatic temperature-dependent shutdown, which is activated if heat draw-off stagnates for a long period whilst there is a high level of insolation.

Operational reliability with ThermProtect

The Vitosol 300-TM is currently the only collector on the market that can be installed horizontally (maximum tube incline of three degrees) and includes ThermProtect automatic temperature-dependent shutdown. It prevents overheating of the collectors when no heat is drawn off and there is a high level of insolation. The Vitosol 300-TM is therefore also suitable for buildings that are not in use all year round, such as residential buildings during holiday periods.

Maximum heat transfer with Duotec

The collector works according to the heat pipe principle, where the solar medium does not flow directly through the tubes. Instead, a process medium evaporates inside the heat pipe and transfers the absorbed heat through condensation to the solar medium via the Duotec double pipe heat exchanger. This method guarantees optimum heat transfer.

Exceptionally long service life

The Vitosol 300-TM is designed for an exceptionally long service life thanks to its high grade, corrosion-resistant materials, including glass, aluminium, copper and stainless steel. The absorber is an integral part of the vacuum tube. This protects it from weather influences and contamination, and ensures high energy yields for years to come.

Quick, easy and safe installation

The above roof installation system with rafter anchors simplifies the task of securing the collectors. The rafter hooks and flanges are designed

to be fixed directly onto the rafters, enabling the collectors to be perfectly integrated into any kind of roof cover. The two mounting rails also save additional time during installation.

In systems with multiple collectors, dark blue cover panels create a seamless visual transition between the collector casing and absorber surfaces. Retaining caps in the base rail in the same colour as the casing prevent tubes from slipping.

Should a service be required, heat pipe tubes can be replaced quickly and easily without having to drain the system due to their dry connection.

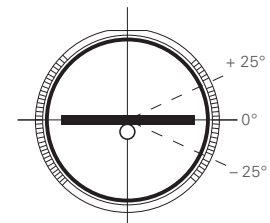

Simple installation and quick absorber alignment through the use of the angular scale on the tube holders

VITOSOL 300-TM

- 1 Collector casing with highly effective thermal insulation
- 2 Duotec double pipe heat exchanger
- 3 Absorber panel with selective coating inside the vacuum tubes
- 4 Heat pipe with ThermProtect automatic temperature-dependent shutdown
- 5 Base rail with tube retainer in the same colour as the casing

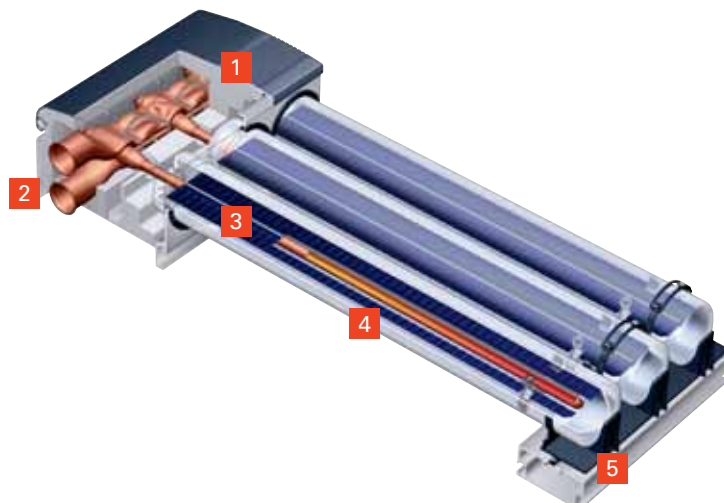



Vitosol 300-TM offers universal application options

TAKE ADVANTAGE OF THESE BENEFITS



Universal application through vertical or horizontal installation in any location, either on rooftops, walls or for freestanding installation.

- + Highly efficient vacuum tube collector based on the heat pipe principle with ThermProtect automatic temperature-dependent shutdown for high operational reliability
- + Protection against overheating during prolonged insolation
- + Long service life thanks to low stagnation temperatures and prevention of steam forming within the system
- + The absorber surfaces with highly selective coating, which are integrated into the vacuum tube, are not susceptible to contamination
- + Efficient heat transfer through condensers fully surrounded by the copper Duotec double pipe heat exchanger
- + Optimum orientation towards the sun thanks to straightforward absorber alignment
- + Dry connection, no contact between process medium and solar medium, i.e. individual tubes can be replaced whilst the system is fully charged
- + Dark blue collector casing and absorber surfaces form a visually seamless whole
- + Highly effective thermal insulation of the header casing for minimum thermal losses
- + Quick and straightforward installation through the Viessmann assembly and connection systems

For specification, see page 26

The Vitosol 200-TM is a highly efficient vacuum tube collector based on the heat pipe principle

The Vitosol 200-TM vacuum tube collector has been designed specifically to be mounted horizontally in large systems on flat roofs, and for apartment buildings. The absorbers can be rotated through 45 degrees to best mirror the path of the sun without increased shading.

Operational reliability with ThermProtect

The new ThermProtect automatic temperature-dependent shutdown function prevents overheating when no heat is drawn off and there is a high level of insolation. The Vitosol 200-TM is therefore also suitable for buildings that are not in use all year round, such as schools.

Maximum heat transfer

The collector works according to the heat pipe principle, where the solar medium does not flow directly through the tubes. Instead, a process medium evaporates inside the heat pipe and transfers the heat through condensation to the solar medium via a copper heat exchanger. This method guarantees maximum, optimum heat transfer and good operating and service properties.

Quickly, simply and safely installed

The header casing does not need to be opened when tubes are inserted. Retaining caps in the base rail prevent tubes from slipping.

Should a service be required, the tubes can be replaced quickly, cost effectively and easily due to their dry connection, without having to drain the system.

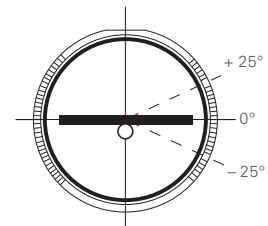

Simple installation and quick absorber alignment through the use of the angular scale on the tube holders

VITOSOL 200-TM

- 1 Collector casing with highly effective thermal insulation
- 2 Dry connection, no contact between process medium and solar medium
- 3 Header for connection on alternate sides
- 4 Absorber panel with selective coating inside the vacuum tubes
- 5 Heat pipe with ThermProtect automatic temperature-dependent shutdown
- 6 Base rail

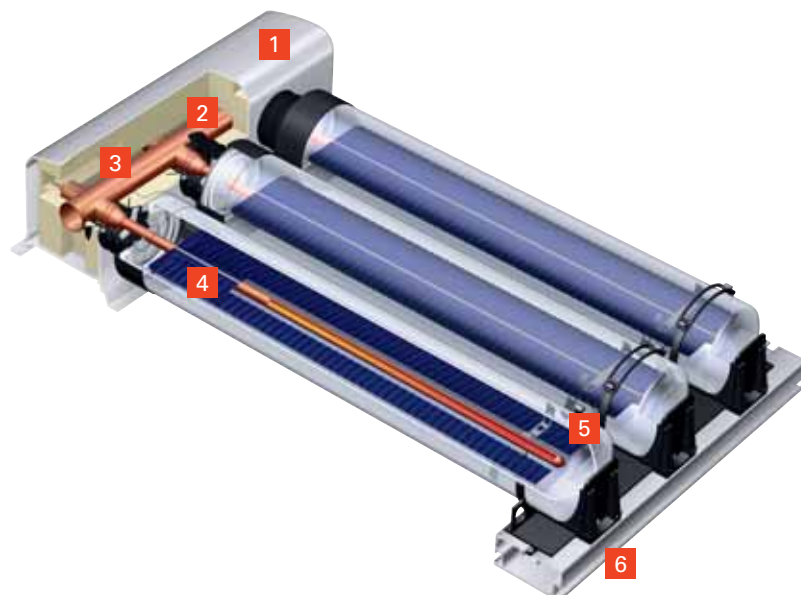



Example of using Vitosol 200-TM tube collectors with ThermProtect



Vitosol 200-TM (type SPEA)

TAKE ADVANTAGE OF THESE BENEFITS

- + Vacuum tube collectors based on the heat pipe principle with ThermProtect automatic temperature-dependent shutdown for high operational reliability
- + Overall system has a long service life thanks to the automatic temperature-dependent shutdown during periods of stagnation in the summer
- + Protection against overheating during prolonged insolation
- + Dry connection, no contact between process medium and solar medium, i.e. individual tubes can be replaced whilst the system is fully charged
- + Greater efficiency means less space is required than for flat-plate collectors
- + Constantly high output without the risk of absorber contamination
- + High levels of solar coverage, therefore suitable for central heating backup
- + Designed for horizontal installation on flat roofs and larger systems
- + Larger tube clearance, so less shading in horizontal flat roof installations
- + Absorber can be rotated by +/- 45 degrees
- + Lower service costs due to longer service life of solar components and pumps thanks to ThermProtect
- + Comparatively low static load on the building due to reduced need for ballast in horizontal installations

For specification, see page 26



VITOSOL 200-FM

VITOSOL 100-FM

Viessmann's patented switching absorber layer protects high performance flat-plate collectors from overheating and stagnation.

The Vitosol 200-FM and Vitosol 100-FM high performance flat-plate collectors are the perfect addition to any heating system. With an individual absorber area of 2.3 square metres, solar collectors can be effectively matched to any energy demand. On average, they can replace up to 60 percent of the energy that would otherwise be required each year for DHW heating, and contribute to central heating backup. When used in conjunction with a condensing boiler, free solar energy can help you reduce your annual energy consumption for heating and DHW by over one third.

ThermProtect prevents overheating

An intelligent absorber layer protects the collectors from overheating. Viessmann's patented ThermProtect technology switches off further energy absorption once it has reached a defined temperature, once the solar cylinder has been fully heated. If the switching temperature is exceeded, the crystalline structure of the absorber layer changes, increasing the rate of heat radiation many times over, and reducing collector output. The stagnation temperature thus drops significantly, preventing the formation of steam.

As the collector temperature falls, the crystalline structure returns to its original state. More than 95 percent of the incoming solar energy is now absorbed and converted into heat. Only the remaining five percent is reflected. There is no limit to the number of times the change in crystalline structure can be activated, making this function permanently available.

ThermProtect also leads to higher yields with the Vitosol 200-FM and Vitosol 100-FM compared to conventional flat-plate collectors, as more generous sizing is possible.

Attractive on any roof

The Vitosol 200-FM is the right choice if the collector is required with a frame in an individual RAL colour. It is finished in dark blue as standard and blends in with practically any roof. The Vitosol 100-FM is only available with an aluminium coloured frame.

The Vitosol 200-FM, type SV2G (vertical) or type SH2G (horizontal) versions, can be selected for seamless roof integration, lying almost flush with the roof cladding when installed.

Permanently sealed and well insulated

The all-round folded aluminium frame and seamless pane mounting ensure permanent tightness and a highly stable collector. The back panel is puncture-proof and corrosion-resistant. Highly effective thermal insulation reduces heat losses, particularly in spring, autumn and winter.

Easy installation

Both collectors are very easy to install. Integral flow and return pipes enable safe installation of even larger collector arrays using flexible stainless steel corrugated pipe push-fit connectors. Up to twelve solar collectors can be easily linked together.



Vitosol 200-FM
Two-family house, Geisenfeld

The flat-plate collectors can be used universally for above roof installation, roof integration and installation on collector supports, for example on flat roofs. The easy-to-assemble Viessmann fixing system consists of load-tested and corrosion-resistant components made from stainless steel and aluminium.



Collector frame with special roof integration profile for fitting the flashing frame

VITOSOL 200-FM

- 1 All-round folded aluminium frame with glazing bead
- 2 Stable, highly transparent cover made from special glass with ThermProtect
- 3 Meander-shaped absorber
- 4 Highly effective thermal insulation
- 5 Absorber panel with ThermProtect coating with automatic temperature-dependent shutdown

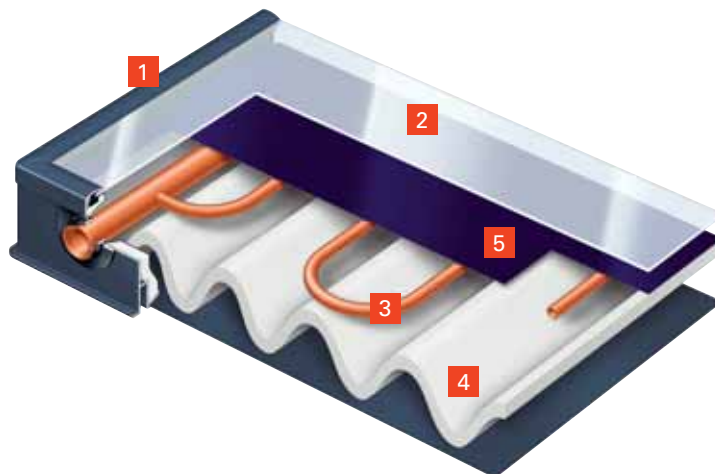



With optional edge trim in all RAL colours, the Vitosol solar collectors blend harmoniously into most roofs.

TAKE ADVANTAGE OF THESE BENEFITS



Vitosol 200-FM with ThermProtect switching absorber layer

- + Vitosol 200-FM and Vitosol 100-FM high performance flat-plate collectors with ThermProtect switching absorber layer
- + No overheating when outside temperatures are high or with low heat transfer
- + Increased solar coverage for central heating backup and DHW heating
- + Permanently sealed by all-round frame and seamless pane mounting
- + Quick and reliable connection through flexible stainless steel corrugated pipe push-fit connectors
- + Universally suitable for above roof installation, flat roof installation, roof integration, or wall mounting
- + Can be installed horizontally or vertically
- + Attractive design, individually finished in any RAL colour (Vitosol 200-FM)

For specification, see pages 26 and 27

The Vitosol 141-FM DHW solar pack uses efficient free solar energy for DHW heating

The Vitosol 141-FM DHW solar pack is particularly suitable for modernisation projects and new build. In terms of size, performance and price, it is intended specifically for detached houses. It provides an environmentally responsible, efficient and economically interesting solution for DHW heating with free solar energy.

The pack comprises two Vitosol 100-FM (type SVKF/SVKG) flat-plate collectors and the dual mode Vitocell 100-B/W DHW cylinder with 250 litre capacity. It is a perfect way to extend a system at the same time as replacing an older boiler, or is ideal for new systems where the use of solar thermal energy is now standard.

ThermProtect prevents overheating

An intelligent absorber layer protects the Vitosol 100-FM collector from overheating. Viessmann's patented

ThermProtect technology switches off further energy absorption once it has reached a defined temperature. If the switching temperature is exceeded, the crystalline structure of the absorber layer changes, increasing the rate of heat radiation many times over, and reducing collector output. The stagnation temperature thus drops significantly, preventing the formation of steam.

As the collector temperature falls, the crystalline structure returns to its original state. More than 95 percent of the incoming solar energy is now absorbed and converted into heat. Only the remaining five percent is reflected. There is no limit to the number of times the change in crystalline structure can be activated, making this function permanently available.

ThermProtect also leads to higher yields with the Vitosol 100-FM compared to conventional flat-plate collectors, as the collectors can be restarted again more quickly if needed.

Dual mode cylinder with Ceraprotect enamel coating

The DHW cylinder with long lasting Ceraprotect enamel coating has two indirect coils for heating by solar collectors and reheating by a boiler. For the solar circuit, the Solar-Divicon with solar control module is already installed at the factory. Highly effective and efficient all-round insulation reduces heat loss.

Straightforward installation

All appliances and components are a perfect match for each other, which makes the installation as easy as can be. Rafter hooks are used for above roof installation. With roof integration, the flat-plate collectors are secured directly to the roof structure. No tools are needed to link the two collectors. The user benefits from the low investment outlay and quick installation of the DHW solar pack.

Improved energy efficiency

By combining solar thermal with a heat generator, energy efficiency class A+ (as a system label) can generally be achieved for the overall heating system.

VITOCELL 100-B

- 1 Inspection and cleaning aperture
- 2 Steel cylinder with Ceraprotect enamel coating
- 3 Magnesium or impressed current anode
- 4 Highly effective all-round thermal insulation
- 5 Upper indirect coil – for reheating by the boiler
- 6 Lower indirect coil – connection for solar collectors
- 7 Solar circuit pump
- 8 Solar-Divicon
- 9 SD1 solar control module

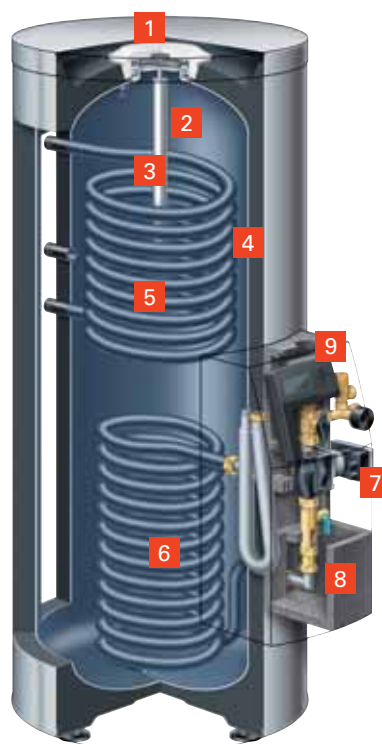



Vitosol 141-FM – solar pack for heating DHW using solar energy with a dual mode DHW cylinder, including Solar-Divicon, solar control unit, solar collectors and solar components

TAKE ADVANTAGE OF THESE BENEFITS



Vitosol 100-FM (type SVK) flat-plate collectors

- + Solar DHW heating for low energy costs
- + Quick and easy connection of the solar thermal system to the DHW cylinder
- + Solar control unit integrated in the Solar-Divicon and prefitted to the cylinder
- + Corrosion protected steel cylinder with Ceraprotect enamel coating
- + Space optimised flat-plate collector with highly selective coating
- + ThermProtect protects collector from overheating
- + Easy collector installation with rafter hooks
- + Collectors installed without tools (push-fit system)
- + High efficiency pump for reduced power consumption
- + Many components are already integrated, saving precious space

For specification, see page 27



VITOSOL 300-TM VACUUM TUBE COLLECTOR

Vitosol 300-TM	Type	type SP3C	type SP3C	type SP3C
Absorber area	m ²	1.26	1.51	3.03
Gross area	m ²	1.98	2.36	4.62
Aperture area	m ²	1.33	1.60	3.19
Dimensions				
Length (depth)	mm	150	150	150
Width	mm	885	1053	2061
Height	mm	2241	2241	2241
Weight	kg	33	39	79



VITOSOL 200-TM VACUUM TUBE COLLECTOR

Vitosol 200-TM	Type	Type SPEA	Type SPEA
Absorber area	m ²	1.63	3.26
Gross area	m ²	2.63	5.25
Aperture area	m ²	1.73	3.46
Dimensions			
Length (depth)	mm	174	174
Width	mm	1174	2364
Height	mm	2244	2244
Weight	kg	57	113



VITOSOL 200-FM FLAT-PLATE COLLECTOR

Vitosol 200-FM	Type	type SV2F	type SH2F	type SV2G	type SH2G
Absorber area	m ²	2.32	2.32	2.32	2.32
Gross area	m ²	2.51	2.51	2.56	2.56
Aperture area	m ²	2.33	2.33	2.33	2.33
Dimensions					
Length (depth)	mm	90	90	90	90
Width	mm	1056	2380	1070	2394
Height	mm	2380	1056	2394	1070
Weight	kg	41	41	41	41



VITOSOL 100-FM FLAT-PLATE COLLECTOR

Vitosol 100-FM	Type	type SV1F	type SH1F
Absorber area	m ²	2.32	2.32
Gross area	m ²	2.51	2.51
Aperture area	m ²	2.33	2.33
Dimensions			
Length (depth)	mm	72	72
Width	mm	1056	2380
Height	mm	2380	1056
Weight	kg	42	42



VITOSOL 141-FM DHW SOLAR PACK

comprising Vitosol 100-FM and Vitocell 100-B/-W

Vitosol 100-FM	Type	Type SVKF	Type SVKG
Absorber area	m ²	2.01	2.01
Gross area	m ²	2.18	2.23
Aperture area	m ²	2.02	2.02
Dimensions			
Length (depth)	mm	73	73
Width	mm	1056	1070
Height	mm	2066	2080
Weight	kg	37	38



Vitocell 100-B/-W with Solar-Divicon	Type	Type CVBA
Cylinder capacity	litres	250
Dimensions		
Length (depth)	mm	1485
Width	mm	860
Height	mm	631
Weight	kg	124

System technology ensures reliable and safe operation

Viessmann supplies you with all the technology you need from a single source.

For the complete solar thermal range, Viessmann offers optimally matching system technology from a single source. All components fit perfectly together. This gives you the guarantee of outstanding efficiency and high operational reliability of your heating and solar thermal system.

Viessmann's comprehensive range includes solar collectors, specially developed combi DHW cylinders for use with solar thermal systems, solar control units, the Solar-Divicon pump module for reliable hydraulics and thermal protection of solar thermal systems, plus oil and gas condensing boilers, wood boilers and heat pumps.

Correctly sized solar thermal systems with matching system components cover up to 60 percent of the annual energy demand for DHW heating of detached and two-family houses, or up to 35 percent of the total demand of low energy houses for DHW and central heating.

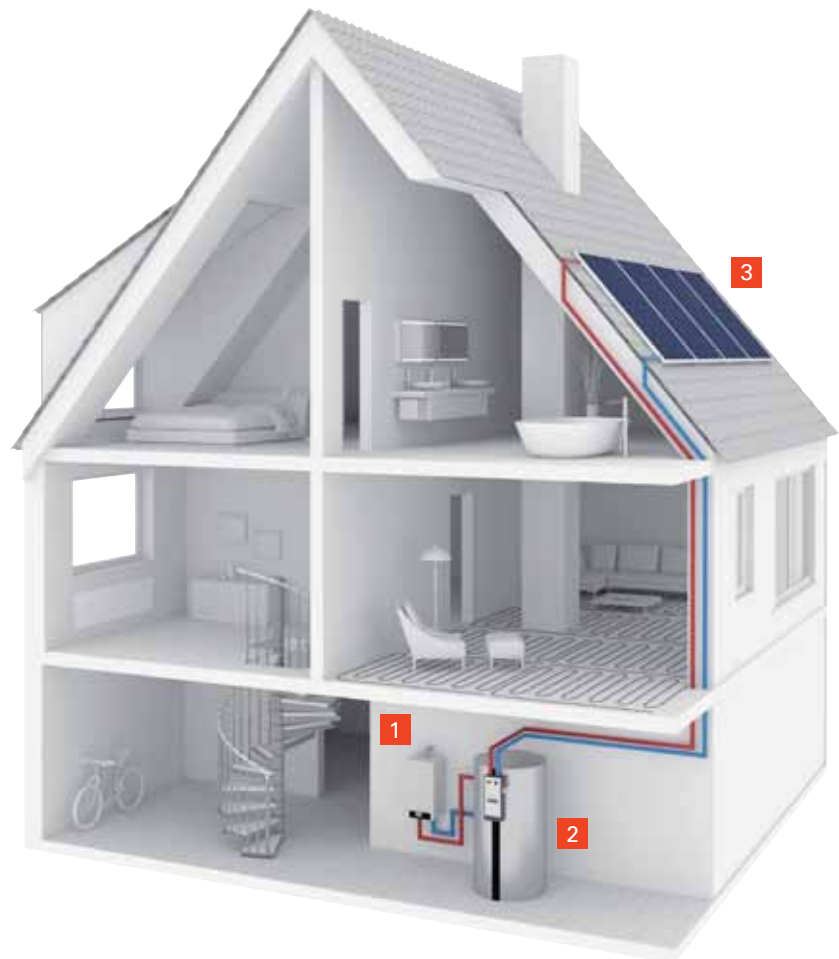

- 1 Vitodens 300-W wall mounted gas condensing boiler
- 2 Vitocell 360-M multi mode combi cylinder for DHW heating and central heating backup with attached Solar-Divicon
- 3 Vitosol 200-FM flat-plate collectors

Energy efficiency class: A
in combination with
solar collectors

A+



CONNECTIVITY

With Vitoconnect* and a smartphone, the operation of your Viessmann heating system couldn't be easier. Heating systems can be controlled with the ViCare app. All apps are available for mobile devices running iOS or Android operating systems.



SOLAR-DIVICON

The solar pump assembly is distinguished by its elegant and compact design. The thermal insulation encases all components and reduces heat losses to a minimum.



SYSTEM ACCESSORIES

Radiators, expansion vessels, pipework systems, pumps, filters and valves – Vitoset offers the complete range of accessories for the Viessmann heating system.

* Only required for appliances without integral WiFi.



SOLAR CONTROL UNITS

With Vitosolic solar control units, solar energy is used particularly effectively. The intelligent energy management system covers all conventional applications and can control up to four separate consumers. By communicating with the Vitotronic boiler control unit, the Vitosolic ensures that optimum use is made of the heat captured by the solar collectors, and that as little additional energy as possible is used for DHW or central heating.



DHW CYLINDERS

The Vitocell range, comprising dual mode DHW cylinders, combi cylinders and heating water buffer cylinders, offers the right cylinder for every demand, and is perfectly matched to the solar thermal system.



Discover more about the Viessmann radiator range



Find out more about Vitocell



At Viessmann, proximity to trade partners is the basis of the company's success. Everyone who chooses Viessmann heating technology benefits from their expertise.

Property developers and system users can receive advice and support regarding sales, installation and customer service exclusively via Viessmann trade partners, who complete regular training at the Viessmann Academy, and have an in-depth knowledge of the company's products.

Every system user benefits from the comprehensive service that all installation contractors offer as standard.

With Viessmann trade partners, you're in good hands

EXAMPLES OF THE SERVICE WE PROVIDE

- Free, no-obligation and individual consultation, even on site
- Clear calculation of heating cost savings after modernisation of the heating system – including systems combined with solar collectors, of course
- Calculation of the payback period, after which the new heating system will have paid for itself through energy savings
- Calculation of the actual heat and DHW demand for the household or property
- Information about an economical combination of a new heating system with a solar thermal system for central heating backup and DHW heating
- Up to date information about public subsidy programmes that could help to finance a new heating system and a solar thermal system
- Support in applying for subsidies

Technology from Viessmann – subsidies from the public purse

You don't just save on running costs. Energy savings and environmentally responsible heating technology is also financially supported by local, regional and national bodies through various subsidies, as well as by power supply utilities [in Germany].

Current information can be found online at www.viessmann.de/foerderprogramme

or ask your trade partner.



Reliable and competent advice from Viessmann employees and contractors on site and at their offices

Attractive finance – invest now and save on heating costs immediately

With the Viessmann finance model, you can start saving straight away, and turn your plans into reality. The fast and reliable process, with no red tape, makes modernisation projects easier, allowing your financial planning to remain flexible. The particular advantage is that with Viessmann's favourable terms, savings on heating costs are generally significantly higher than finance costs.

Please note

Applications for subsidies and finance must be made before the heating and/or solar thermal system is purchased. Subsidies and finance agreements cannot be arranged retrospectively.

Terms and conditions to shout about

If you invest now in a new heating system for your property, you may be eligible for an attractive finance package from Viessmann in conjunction with CreditPlus bank: just 3.99 percent* effective APR.

CreditPlus

* Over 24 months

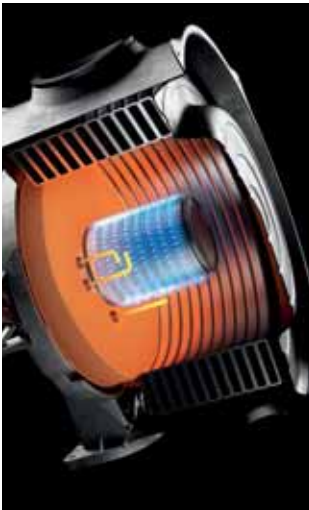

MatriX-Plus burner

Viessmann comprehensive range

- Boilers for oil or gas
- Combined heat and power generation
- Hybrid appliances
- Heat pumps
- Wood combustion technology
- Biogas production plants
- Biogas upgrading plants
- Solar thermal
- Photovoltaic
- Electric heating/DHW systems
- Refrigeration systems
- Accessories

Milestones of heating technology

As an environmental pioneer and technological trailblazer for the heating sector, Viessmann has been supplying exceptionally clean and efficient systems for heating, refrigeration and decentralised power generation for decades. Many of the company's developments are recognised as heating equipment milestones.

Sustainability in action

As a family business Viessmann takes the long view and places great value on acting responsibly; sustainability is firmly enshrined in the company's principles. For Viessmann, sustainability in action means striking a balance between economy, ecology and social responsibility throughout the company; meeting current needs without compromising the quality of life of future generations.

With its strategic sustainability project, Viessmann demonstrates at its own head office in Allendorf (Eder) that the energy and climate policy goals set by the German government for 2050 can in fact be achieved today with the help of commercially available technology.



We create living spaces
for generations to come.



Number 1 Trade Partner for the 15th consecutive time

Practical partnership

As part of its comprehensive range, Viessmann also offers a wide selection of complementary services. These services include a comprehensive training and further development programme for trade partners at the well equipped training facilities of the Viessmann Academy.

With its new digital services, Viessmann offers innovative solutions such as the operation and monitoring of heating systems by smartphone. Users benefit from greater reassurance and convenience, whilst contractors can keep a constant eye on the systems for which they are responsible.



Viessmann is a leading international manufacturer of efficient energy systems.

VISSMANN GROUP IN FIGURES

1917

— Viessmann was founded

12,000

— employees

2.5

— Group turnover in billions of euros

54

— export share in percent

23

— production companies in

12

— countries

120

— sales offices worldwide

74

— countries with agents and sales companies



Viessmann Werke GmbH & Co. KG
35107 Allendorf (Eder)
Germany
Telephone +49 (0)6452 70-0
www.viessmann.com

Your trade partner

9449 592 - 9 GB 07/2019

Copyright Viessmann.
Duplication and alternative use
only with prior written consent.
Subject to modifications.
