



Osnovne informacije

Grupa proizvoda	TeSys
Grupa proizvoda	TeSys F
Tip proizvoda ili komponente	Kontaktör
Kratko ime uređaja	LC1F
Primena kontaktora	Upravljanje motorom Rezistivno opterećenje
Kategorija upotrebe	AC-4 AC-1 AC-3
Broj polova	3P
[ue] nazivni napon	\leq 1000 V AC 50/60 Hz \leq 460 V DC
Napon upravljačkog kola	220...230 V DC 220...240 V AC 40...400 Hz
[ie] nazivna struja	1000 A 40 °C) pri \leq 440 V AC AC-1 800 A 55 °C) pri \leq 440 V AC AC-3

Dopunske informacije

[uimp] nazivni podnosivi impulsni napon	8 kV
[ith] dozvoljena termička struja u vazduhu	1000 A pri <40 °C
Nazivna prekidna moć	6400 A u skladu sa IEC 60947-4-1
[icw] kratkotrajna podnosiva struja kratkog spoja	5500 A pri <40 °C - 10 s 4600 A pri <40 °C - 30 s 3600 A pri <40 °C - 1 min 2600 A pri <40 °C - 3 min 1700 A pri <40 °C - 10 min
Pripadajući osigurač	1000 A gG pri \leq 440 V 800 A aM pri \leq 440 V
Prosečna impedansa	0,12 m Ω - Ith 1000 A 50 Hz
[ui] nazivni napon izolacije	1000 V u skladu sa IEC 60947-4-1 1500 V u skladu sa VDE 0110 grupa C
Snaga disipacije po polu	120 W AC-1 77 W AC-3
Kategorija prenapona	III
Power pole contact composition	3 NO
Snaga motora kw	450 KW pri 1000 V AC 50/60 Hz (AC-3) 450 KW pri 500 V AC 50/60 Hz (AC-3) 475 KW pri 660...690 V AC 50/60 Hz (AC-3) 110 KW pri 400 V AC 50/60 Hz (AC-4) 450 KW pri 380...400 V AC 50/60 Hz (AC-3) 450 KW pri 415 V AC 50/60 Hz (AC-3) 450 KW pri 440 V AC 50/60 Hz (AC-3) 250 kW pri 220...230 V AC 50/60 Hz (AC-3)
Ograničenje napona upravljačkog kola	U radu: 0.85...1.1 U _c 55 °C) Propad napona: 0.3...0.5 U _c 55 °C)
Mehanička trajnost	5 miliona ciklusa
Udarna snaga u W	1900 W 20 °C)
Snaga držanja u w	12 W pri 20 °C
Maksimalni radni ciklus	600 ciklusa/h pri <55 °C
Vreme uključanja/isključanja	40...50 ms otvaranje 60...80 ms zatvaranje

Povezivanje - priključci	Upravljačko kolo: vijčani priključni blokovi 1 kabl(ovi) 1...4 mm ² fleksibilni bez kablovskog završetka Upravljačko kolo: vijčani priključni blokovi 2 kabl(ovi) 1...4 mm ² fleksibilni bez kablovskog završetka Upravljačko kolo: vijčani priključni blokovi 1 kabl(ovi) 1...4 mm ² fleksibilni sa Upravljačko kolo: vijčani priključni blokovi 2 kabl(ovi) 1...2,5 mm ² fleksibilni sa Upravljačko kolo: vijčani priključni blokovi 1 kabl(ovi) 1...4 mm ² jednožični bez kablovskog završetka Upravljačko kolo: vijčani priključni blokovi 2 kabl(ovi) 1...4 mm ² jednožični bez kablovskog završetka Kolo napajanja: sabirnica 2 kabl(ovi) - poprečni presek sabirnice: 60 x 5 mm Kolo napajanja: povezivanje na zavrtanj
Moment pritezanja	Upravljačko kolo: 1,2 N.m Kolo napajanja: 58 N.m
Nosači za montažu	Ploča
Disipacija toplote	12 W
Motor power range	250...500 KW pri 200...240 V trofazne 250...500 KW pri 380...440 V trofazne 110...220 KW pri 200...240 V trofazne 250...500 kW pri 480...500 V trofazne
Tip motornog pokretača	Kontaktor za direktno puštanje u rad
Napon kalema kontaktora	220 V DC standardno 230 V DC standardno 220 V AC standardno 230 V AC standardno 240 V AC standardno
Standardi	IEC 60947-1 JIS C8201-4-1 EN 60947-4-1 EN 60947-1 IEC 60947-4-1
Sertifikacija proizvoda	ABS UL CCC CSA RMRoS CB UKCA
Kompatibilnost	LC1F
Tip upravljačkog kola	DC standardno AC pri 40...400 Hz

Okruženje

Ip stepen zaštite	IP20 prednja strana sa poklopcima u skladu sa IEC 60529 IP20 prednja strana sa poklopcima u skladu sa VDE 0106
Zaštitni tretman	TH
Temperatura okoline za rad uređaja	-5...55 °C
Temperatura okoline za skladištenje	-60...80 °C
Dopustiva temperatura u okolini uređaja	-5...55 °C
Visina	304 mm
Širina	309 mm
Dubina	255 mm
Nadmorska visina za rad uređaja	3000 m bez smanjenja karakteristika
Masa proizvoda	18,75 kg

Pakovanje

Unit Type of Package 1	PCE
Number of Units in Package 1	1
Package 1 Height	33,5 cm
Package 1 Width	33 cm
Package 1 Length	44 cm
Package 1 Weight	18,455 kg
Unit Type of Package 2	P06
Number of Units in Package 2	4
Package 2 Height	75 cm

Package 2 Width	60 cm
Package 2 Length	80 cm
Package 2 Weight	82,32 kg

Održivost ponude

Status održive ponude	Green Premium proizvod
Propis REACh	REACh Deklaracija
EU RoHS direktiva	Usaglašeno EU RoHS Deklaracija
Bez žive	Da
Informacije o RoHS izuzecima	Da
RoHS regulativa za Kinu	RoHS Deklaracija Za Kinu
Izjava o zaštiti okoliša	Profil Ekološke Prihvatljivosti Proizvoda
Profil cirkularnosti	Informacije O Kraju Radnog Veka
WEEE	Ovaj proizvod je na tržištima Evropske unije neophodno odložiti u skladu sa specifičnim smernicama za prikupljanje otpada i nikako ne sme da dospe u kontejnere za otpatke.

Ugovorna garancija

Garancija	18 meseci
-----------	-----------

Dimensions and Drawings

LC1 F630 and F800

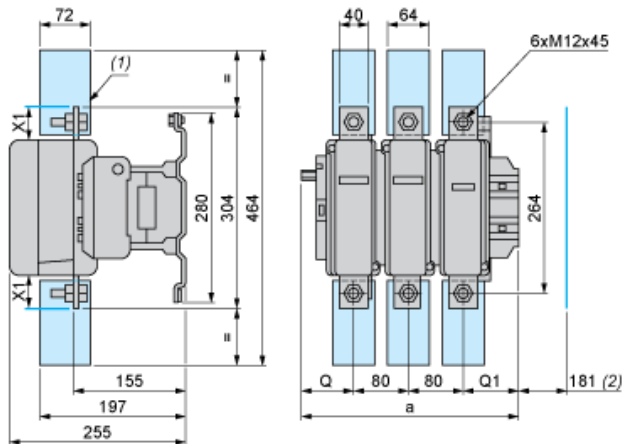

- (1) Power terminal protection shroud.
- (2) Minimum distance required for coil removal.

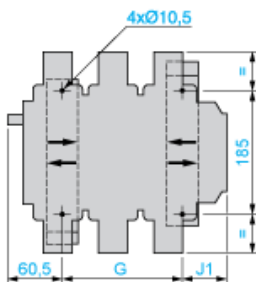

NOTE: X1 (mm) = Minimum electrical clearance according to operating voltage and breaking capacity.

LC1		a	G supplied	G min.	G max.	J1	Q	Q1
F630	2P	309	180	100	195	68.5	102	127
F630, F800	3P	309	180	100	195	68.5	60	89
F630	4P	389	240	150	275	88.5	60	89
Voltage	200...500 V		690...1000 V		200...690 V		1000 V	
LC1 F630	20		30		-		-	
LC1 F800	-		-		10		20	

TeSys F reversing contactors and changeover contactor pairs Vertically mounted

NOTE: For customer assembly, with mechanical interlock (MI) LA9 F, fixing recommended on AM1 EC uprights (please consult your Regional Sales Office). 2 x LC1 identical or different ratings (LC1 F115 to F630 and F800).

Assembly A

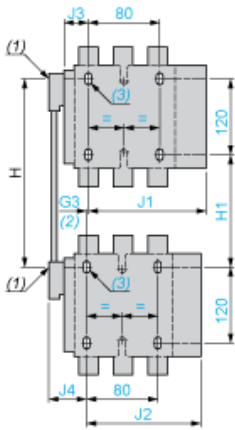

- (1) Mechanical interlock shaft.
- (2) For assembly of contactors of different ratings only.
- (3) 4 x Ø6.5 for LC1 F115 to F225.

Assembly A⁽⁷⁾ - Mechanical interlock reference

	G3 3P	G3 4P	H min.	H max.	H1 min.	H1 max.	J1 3P	J1 4P
LA9 FF4F	0	0	200	310	80	190	137	155.5
LA9 FG4F	3	4	210	300	90	180	139.5	159.5
LA9 FG4G	0	0	220	310	100	190	139.5	159.5

	J2 3P	J2 4P	J3 3P	J3 4P	J4 3P	J4 4P
LA9 FF4F	137	155.5	48.5	67	48.5	67
LA9 FG4F	137	155.5	53	73	54	69
LA9 FG4G	139.5	159.5	53	73	53	73

Assembly B

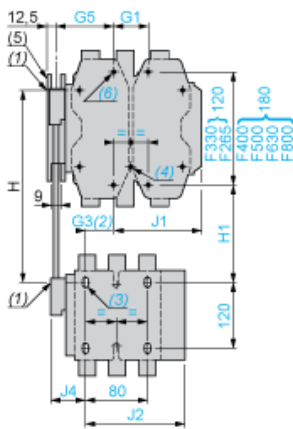

- (4) 4 x Ø6.5 for LC1 F265.
- (5) Mechanical interlock guide bracket.

Assembly B⁽⁷⁾ - Mechanical interlock reference

	G1 3P	G1 4P	G3 3P	G3 4P	G5 3P	G5 4P	H min.	H max.
LA9 FH4F	96	96	21	27	60	83	240	380
LA9 FJ4F	80	80	45	26	83	83	250	380
LA9 FK4F	80	140	45	26	83	83	270	380
LA9 FL4F	180	240	35	17	74	74	310	380
LA9 FH4G	96	96	19	23	60	83	250	380
LA9 FJ4G	80	80	42	22	83	83	250	380
LA9 FK4G	80	140	42	22	83	83	270	380
LA9 FL4G	180	240	33	13	74	74	310	380

	H1 min.	H1 max.	J1 3P	J1 4P	J2 3P	J2 4P	J4 3P	J4 4P
LA9 FH4F	110	250	157.5	181.5	137	155.5	48.5	67
LA9 FJ4F	80	210	144.5	192.5	137	155.5	48.5	67

	H1 min.	H1 max.	J1 3P	J1 4P	J2 3P	J2 4P	J4 3P	J4 4P
LA9 FK4F	100	210	164.5	219.5	137	155.5	48.5	67
LA9 FL4F	140	210	248.5	328.5	137	155.5	48.5	67
LA9 FH4G	120	250	157.5	181.5	139.5	159.5	53	73
LA9 FJ4G	90	220	144.5	192.5	139.5	159.5	53	73
LA9 FK4G	110	220	164.5	219.5	139.5	159.5	53	73
LA9 FL4G	150	220	248.5	328.5	139.5	159.5	53	73

Assembly C

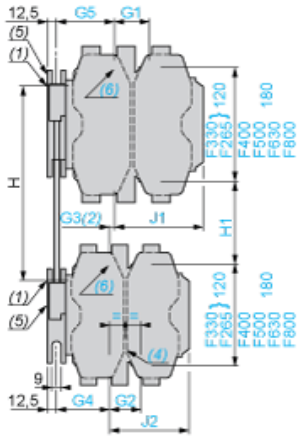

(6) 4 x Ø8.5 for LC1 F400, F500 or 4 x Ø10.5 for LC1 F630 and F800.

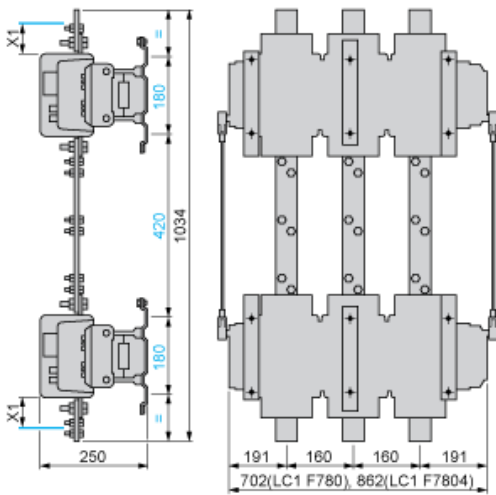

(7) Only 3P for F800.

(8) In this case, G4 is greater than G5.

Assembly C⁽⁷⁾

	G1 3P	G1 4P	G2 3P	G2 4P	G3 3P	G3 4P	G4 3P	G4 4P	G5 3P	G5 4P
LA9 FH4H	96	96	96	96	0	0	60	83	60	83
LA9 FJ4H	80	80	96	96	23	0	60	83	83	83
LA9 FK4H	80	140	96	96	23	0	60	83	83	83
LA9 FL4H	180	240	96	96	14	g ⁽⁸⁾	60	83	74	74
LA9 FJ4J	80	80	80	80	0	0	83	83	83	83
LA9 FK4J	80	140	80	80	0	0	83	83	83	83
LA9 FL4J	180	240	80	80	g ⁽⁸⁾	g ⁽⁸⁾	83	83	74	74
LA9 FK4K	80	140	80	140	0	0	83	83	83	83
LA9 FL4K	180	240	80	140	g ⁽⁸⁾	g ⁽⁸⁾	83	83	74	74
LA9 FL4L	180	240	180	240	0	0	74	74	74	74

	H min.	H max.	H1 min.	H1 max.	J1 3P	J1 4P	J2 3P	J2 4P
LA9 FH4H	250	380	130	260	157.5	181.5	157.5	181.5

	H min.	H max.	H1 min.	H1 max.	J1 3P	J1 4P	J2 3P	J2 4P
LA9 FJ4H	260	380	110	230	144.5	192.5	157.5	181.5
LA9 FK4H	280	380	130	230	164.5	219.5	157.5	181.5
LA9 FL4H	330	380	170	220	248.5	328.5	157.5	181.5
LA9 FJ4J	260	380	60	200	144.5	192.5	144.5	192.5
LA9 FK4J	280	380	100	200	164.5	219.5	144.5	192.5
LA9 FL4J	325	380	140	195	248.5	329.5	144.5	192.5
LA9 FK4K	300	380	120	200	164.5	329.5	164.5	219.5
LA9 FL4K	345	380	160	195	248.5	328.5	164.5	219.5
LA9 FL4L	380	380	200	200	248.5	328.5	248.5	328.5

Connections and Schema

2, 3, and 4-pole Contactors

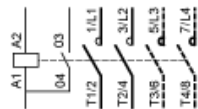

LC1 F115 to F630, F1250 (coil LX1 F ~)



LC1 F115 to F630 , F1250 (coil LX4 F ≡)

LC1 F115 to F265 (coil LX9 F ~)

LC1 F800 (coil LX8 F ~ / ≡)

