



Osnovne informacije

Grupa proizvoda	Harmony XVU
Tip proizvoda ili komponente	Modularna svetleća kolona
Pribor / posebni tip	Ploča za fiksiranje
Pribor / posebna kategorija	Pribor za montažu
Ime komponente	XVU
Prečnik za montiranje	60 mm

Dopunske informacije

Visina stuba	100 mm
Nosači za montažu	Ploča sa stubom
Kompatibilnost proizvoda	Vrh: AC kućište Vrh: DC kućište Vrh: okretni nosač
Materijal	PBT (polibutilen-tereftalat) V-0 otpornost na plamen u skladu sa UL 94 ABS (akrilonitril-butadien-stiren) PC (polikarbonat) Aluminijum
Boja kućišta	Crna
Povezivanje - priključci	Pritiskom
[us] nazivni napon napajanja	24 V AC/DC 110...240 V AC
Dužina	117 mm
Masa proizvoda	0,132 kg

Okruženje

Temperatura okoline za skladištenje	-40...70 °C
Temperatura okoline za rad uređaja	-25...50 °C
Ip stepen zaštite	IP65
Sertifikacija proizvoda	CSA UL CE

Pakovanje

Unit Type of Package 1	PCE
Number of Units in Package 1	1
Package 1 Height	9,1 cm
Package 1 Width	26,8 cm
Package 1 Length	9,0 cm
Package 1 Weight	285,0 g
Unit Type of Package 2	S03
Number of Units in Package 2	12
Package 2 Height	30,0 cm
Package 2 Width	30,0 cm
Package 2 Length	40,0 cm
Package 2 Weight	4,481 kg

Unit Type of Package 3	PAL
Number of Units in Package 3	96
Package 3 Height	60,0 cm
Package 3 Width	80,0 cm
Package 3 Length	70,0 cm
Package 3 Weight	35,36 kg

Održivost ponude

Status održive ponude	Green Premium proizvod
Propis REACH	REACH Deklaracija
EU RoHS direktiva	Proaktivna usaglašenost (proizvod nije u zakonskom okviru direktive EU RoHS) EU RoHS deklaracija
Bez žive	Da
Informacije o RoHS izuzecima	Da
RoHS regulativa za Kinu	RoHS Deklaracija Za Kinu
Izjava o zaštiti okoliša	Profil Ekološke Prihvatljivosti Proizvoda
Profil cirkularnosti	Informacije O Kraju Radnog Veka

Fixing Unit - Plate with Pole

Dimensions

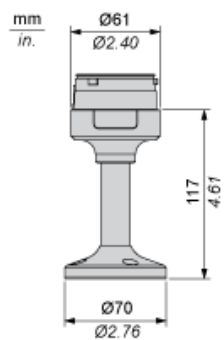

Modular Tower Lights Mounting

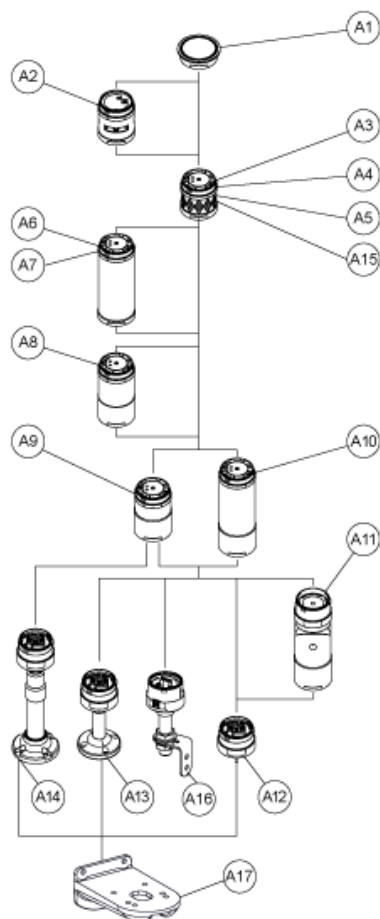

Drawing	Part number	Part name
A1	-	Top cover
-	Top cover (Silver)	
A2	XVUC9S	Buzzer unit
XVUC9SQ	Buzzer unit (Silver)	
A3	XVUC23	Green LED unit
XVUC24	Red LED unit	
XVUC25	Orange LED unit	
XVUC26	Blue LED unit	
XVUC27	White LED unit	
XVUC28	Yellow LED unit	
A4	XVUC29	Multi-LED unit
A5	XVUC29P	Multi-LED unit, Pulse signal
A6	XVUC9V	Sound unit
A7	XVUC9VP	Sound unit, Pulse signal
A8	XVUC020	Extender
XVUC020Q	Extender (Silver)	
A9	XVUC21B	DC body

Drawing	Part number	Part name
XVUC21BQ	DC body (Silver)	
A10	XVUC21M	AC body NPN
XVUC21MP	AC body PNP	
XVUC21MQP	AC body PNP (Silver)	
A11	XVUZ06	Flexible option
A12	XVUZ01	Fixing Unit - Direct mounting (3 pins)
XVUZ01Q	Fixing Unit - Direct mounting (Silver,3 pins)	
XVUZ03	Fixing Unit - Direct mounting (2 pins)	
XVUZ04	Fixing Unit - Direct mounting (4 pins)	
A13	XVUZ02	Fixing Unit - Plate with Pole (100 mm)
XVUZ02Q	Fixing Unit - Plate with Pole (100 mm, Silver)	
XVUZ400	Fixing Unit - Plate with Pole (400 mm)	
XVUZ800	Fixing Unit - Plate with Pole (800 mm)	
A14	XVUZ05	Fixing Unit - Plate with adjustment pole (100-385 mm)
A15	XVUC43	Green LED unit, Flash
XVUC44	Red LED unit, Flash	
XVUC45	Orange LED unit, Flash	
XVUC46	Blue LED unit, Flash	
XVUC47	White LED unit, Flash	
XVUC48	Yellow LED unit, Flash	
A16	XVUZ100T	Fixing Unit - Metal bracket with pole (100 mm)
XVUZ250T	Fixing Unit - Metal bracket with pole(250 mm)	
XVUZ400T	Fixing Unit - Metal bracket with pole (400 mm)	
A17	XVUZ12	Fixing plate for use on vertical support - black

Modular Tower Lights Mounting

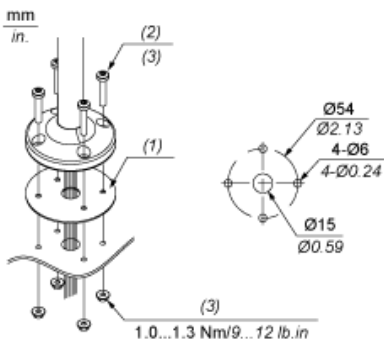

- (1) Gasket
- (2) Screw x 4 (unattached)
- (3) M5 x (thickness+10 mm /0.39 in.)

Illuminated Units, Multi-LED and Audible Units Wiring

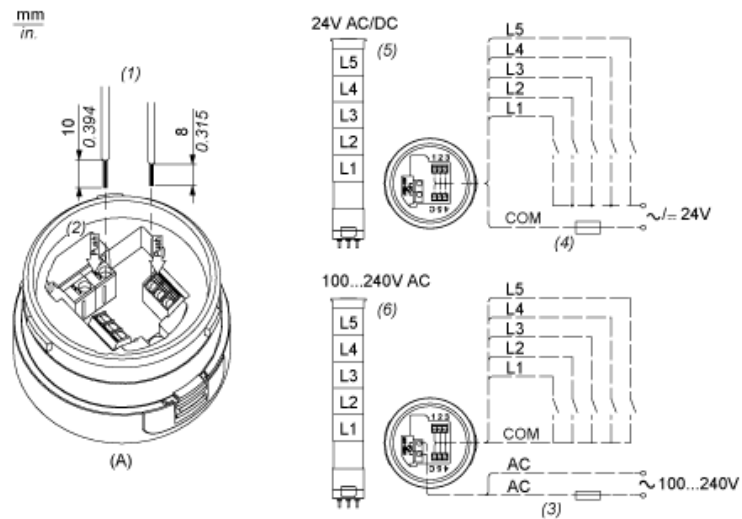

- (A) Fixing Unit
 - (1) Dimensions of Wiring size
 - (2) Push-in Wire Connectors
 - (3) Fuse : 2A ,250V
 - (4) Fuse : 0.5A ,125V
 - (5) Modular Tower Lights 24V AC/DC
 - (6) Modular Tower Lights 100...240V AC
- L1 to Illuminated LED Units
 L5 :